



**JS-1031B Four-colors Double-side
High-speed Rotational Belt Printer
Operation Manual**

**JS-1031B 四色双面高速轮转印带机
使用说明书**

Ruian Jingda Printing Machinery Co., Ltd

瑞安市景大印刷机械有限公司

**Add: Sandu, Dongchen Village Industry, Tangxia Town,
Ruian City, Zhejiang, China.**

地址：中国浙江省瑞安市塘下镇三都东陈村工业区

Tel (电话) : +86-577-65337601

Fax (传真): +86-577-65337602

Website (网址) : <http://www.cnjdyj.cn>

E-mail (邮箱) : zhong@cnjdyj.cn



Content

- I. JS-1031B Model Overall Figure
- II. Operation Brief Introduction of Printing Machine
- III. Plate Cylinder and Register
- IV. Roller and Duct
- V. Maintenance and Lubricating Method of Printing Machine
- VI. Electric Control
- VII. Trouble and Troubleshooting Method

JS-1031B Model Overall Figure

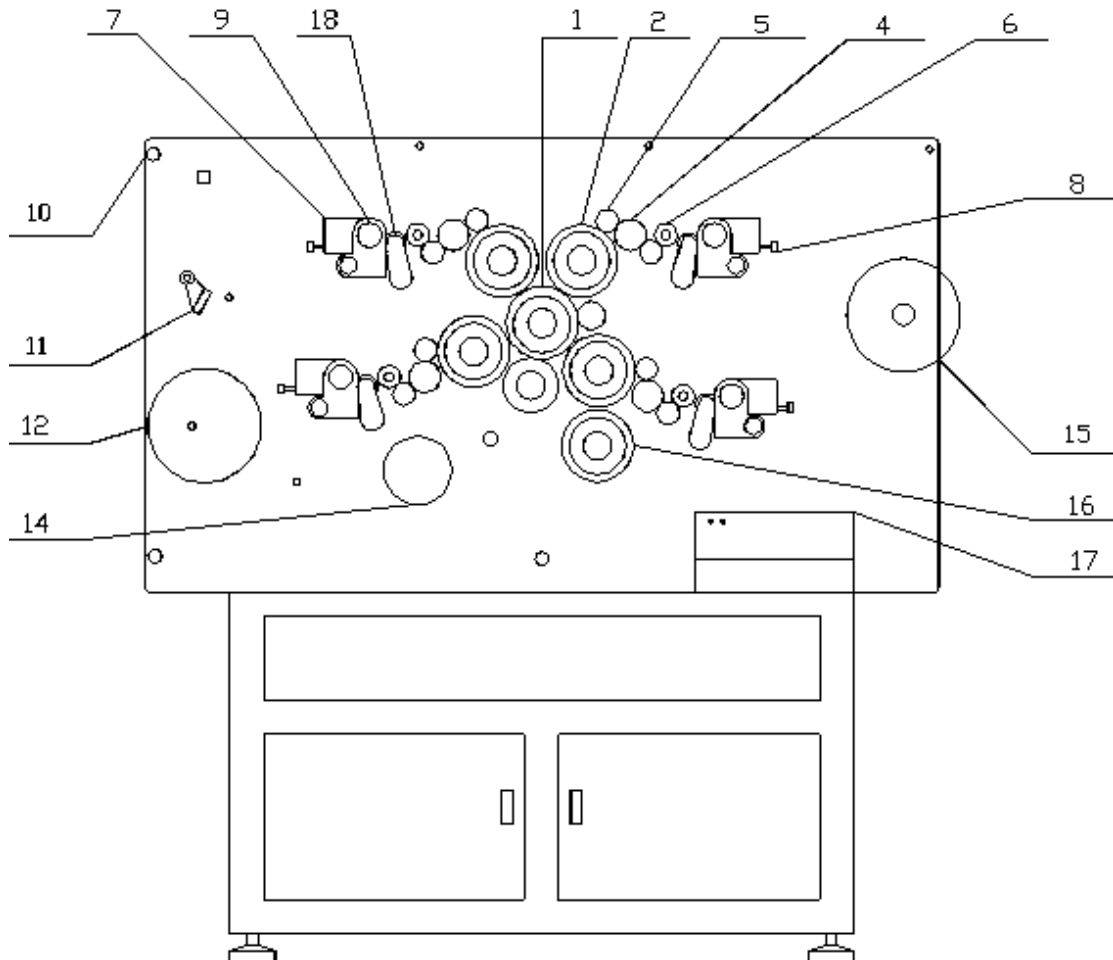

- 1. Twice Diameter Blanket Cylinder 2. Printing Cylinder
- 3. Impression Cylinder 4. Ink Vibrator 5. Form Inking Roller
- 6. Supply Roller 7. Duct 8. Adjustable Screw of Ink Quantity
- 9. Hand Wheel of Stopping Ink 10. Guide Drum
- 11. Photoelectric Switch 12. Winding Frame 13. Rolling Shaft
- 14. Tensioning Wheel 15. Wrap up Shaft
- 16. Back Side Printing Cylinder 17. Operation Control Board

Picture of label tape through of machine

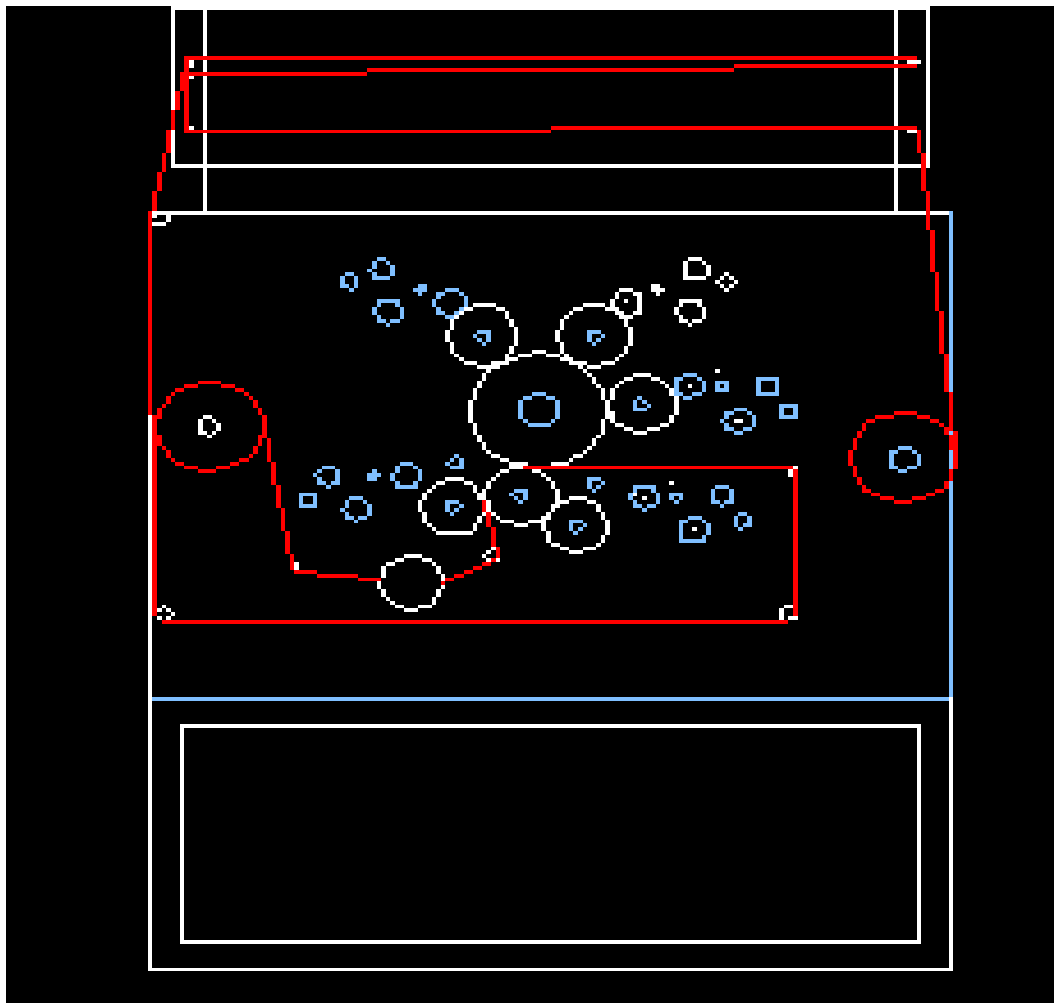

II. Operation Brief Introduction of Printing Machine

JS-1031B Model High-speed Rotary Machine is a satellite Letterpress Rotary Machine with resin offset as well as dual-side printing.

The printing parts are composed of blanket cylinder and printing roller as well as inking transmission circuit etc. illustrated as its overall figure 1.

Twice diameter blanket cylinder is positioned by four screws' shaft, when sticking the blanket, loosen the screws, take the blanket cylinder off, stick the special double-side tape on the offset device, then paste the blanket

with tidy level. (If the double-side tape is not pasted on, you can grit with abrasive paper, because the dirty may be on the roller), then install it on the printing machine, press it with embossing rolling ③ turn the machine to press the blanket flat, the shaft core of the press printing roller is a kind of structure of eccentric structure, it can adjust the pressure. The shaft core of printing roller② is also a kind of eccentric adjusting structure (illustrated Fig.1-2), it is used in adjusting its printing pressure. The inking transmission circuit are composed of wavers ④ , inking roller⑤, inking supplying⑥, glue roller, duct used for storing ink, glue roller and ink roller are used for transmission ink, the wavers is used for evening the ink. The ink can be controlled by screws ⑧ adjusting. If it needs stopping, turn the OFF hand wheel.

III. Plate Cylinder and Register

It is an exquisite mechanism composed of eccentric shaft sleeve①, gear ② bearing③, interior jacket④, offset sleeve and positioning sleeve⑦ (illustrated as followed)

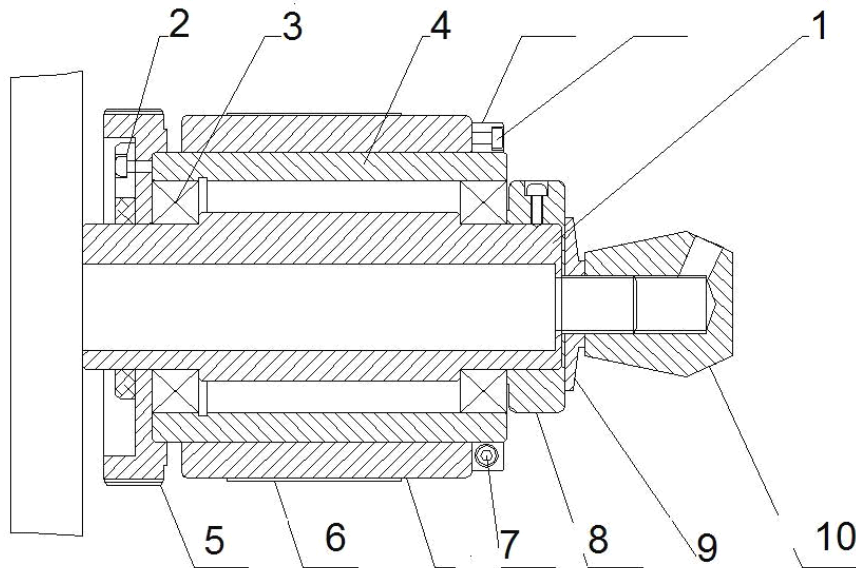

Fig.1-2

When working, paste the resin with pattern on the printing roller by double-side tape (it is equipped with special register table), then install it on the interior sleeve ④, fasten the screws, then turn the hand wheel ⑧ pressing the rubber roller, the pressure must be moderate (because the printing pressure is too heavy , it maybe damages the precision of the machine), then turn the printing machine to transfer the oil to the blanket and observe whether the pattern is clear or not. If is not clear, it is maybe caused by three aspects: one is the pressure is too heavy, the other is the ink is too much(because it is a new machine, the brake⑤ is absolutely no problem), the last is the positioning sleeve ⑦ is too loose. How to offset as fast as possible every new customer will face that problem. Coloring method has two: horizontal and vertical coloring, the horizontal coloring is comparatively simple.

Illustrated as Fig. 1-2, loosen the screws of positioning sleeve ⑦, knock

the plate cylinder ⑥ by rubber hammer and move it left and right

Let's look at the following pictures for vertical sleeve:

Dotted Line Makeup 虚线版 Solid Line Makeup 实线版 Plate
Cylinder 1 印筒 1 anticlockwise 逆时针 Plate Cylinder 2 印筒 2
Blanket Cylinder 橡皮筒 Dotted Line 虚线 Solid Line 实线
Printing Materials 印物

Firstly, illustrated as the figures, the plate cylinder ① as reference is fixed without any change. We regard the time as standard, if it belongs to the above illustration; the broken line is on the real line. The plate cylinder ② with anticlockwise direction turn to the relative position. If the broken line is under the real line, it must be turned with clockwise direction.

Then look at the line printed on the belt, we will find the direction of broken line is different from the direction of the rubber cloth. The broken line is under the real line, turn the plate cylinder ② with anticlockwise direction, do not put the wrong direction of the pattern of rubber cloth as well as the position of the printed products.

IV. Roller and Duct

The material of glue roller equipped on the printing machine is made up of polyurethane through grinding and rubbing, its Shore hardness is 30° , illustrated as JS-1061B Overall figure, the part of transferring ink ⑥ and ⑩ are glue roller with the functions of transferring ink, its pressure is

4-5mm, if it is no need to work, take them out, because of long time of pressure, it will cause out of shape.

Duct illustrated as following:

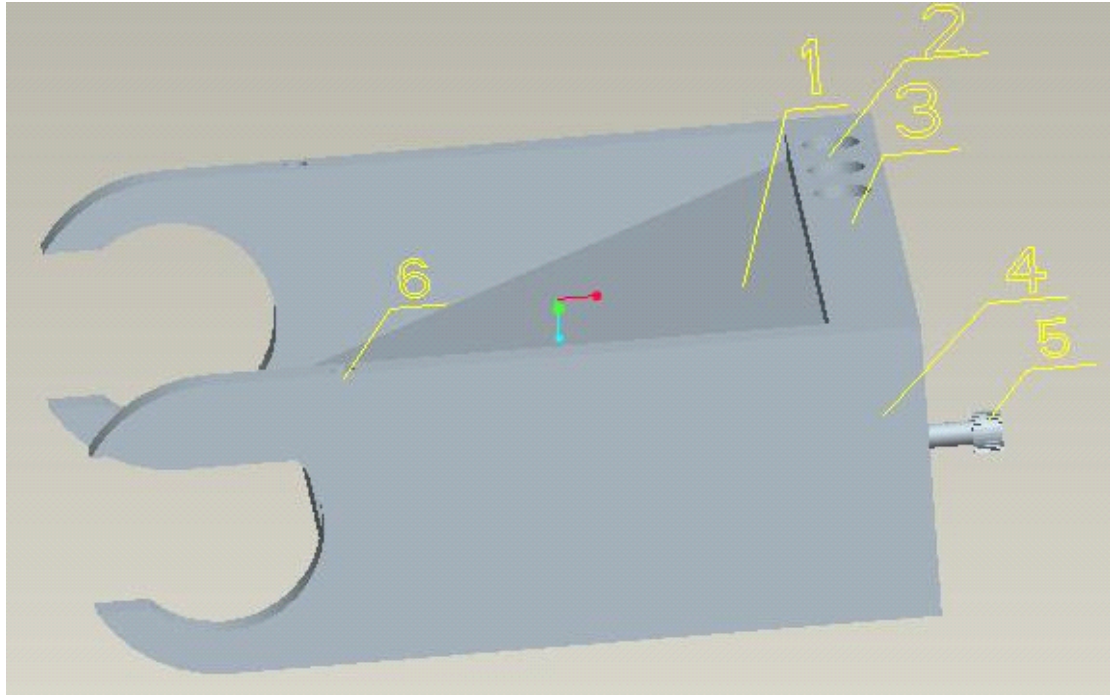

The part of duct is a very precise part of the machine, the blade ① is fixed on the lean steel plate by screws ② and bar ③. The adjusting screw ④ is used for adjusting the gap between the blades, as well as control the ink volume and evenness. Oil hole ⑤ is used for adding the lubricating oil to lubricate duct and shaft. A new machine must be added with oil. If it needs to rinse the oil, turn the adjusting screw up to the trough, and then pull it out. When wanting to replace it, please be careful and steady.

V. Maintenance and Lubrication of Printing Machine

The key to the maintenance of a machine is to prevent the wear and tear

and accident of the machine from happening. To this end, it is required that the machine be properly adjusted, cleaned, lubricated and examined.

I. Cleaning of the Machine

Cleaning is an important method in the maintenance of the machine. If the machine is kept clean, its life will be lengthened, the wear and tear minimized, and the possible accident prevented. The following are the notices for cleaning the machine:

1. The power must be in OFF position.
2. Macerated fabric or rags should not be used in case it is dropped inside the machine.
3. Check if the oil hole is blocked.
4. Check if there is wear and tear in spares, if the bolts and nuts are loosened.
5. Attention should be paid to safety matters to avoid possible accidents.
6. When the cleaning is finished, overall examination must be made of the machine to see if there is anything unwanted dropped inside the machine so as not to cause accidents.
7. When cleaning the working place, try not to let dirt fly and infiltrate into the gears and bearings.

NB. While cleaning the machine, the garbage under the machine body, the oil accumulated in the oil plate, and the grease on the pedal all should

be cleared. If the machine is not in use for some time, it should be covered to prevent dirt or sand from coming in.

II. Maintenance of Printing Machine

The maintenance of the printing machine is very important technical work in eliminating possible accident and keeping the machine in good order. The maintenance of the printing machine in a factory adopts a 3-level system.

The first level maintenance refers to the routine checkup of the machine, which demands that the operator make a careful examination of the printer on every shift. Not only should he add oil to the lubricating positions according to rules, but he also observe the conditions of the spares in the production process. He should listen to the sound of the machine in operation to see if there are any abnormalities. In relieving the shift, he should notify to the person of the next shift the adjustment and problems of the machine.

The second level of maintenance refers to the weekly checkup of the machine. During this process, the printer should be stopped for about 2 hours. It is required that, apart from the overall cleaning of the machine, important parts and positions be checked and adjusted so as to keep the oil path smooth, the position of the spares correct, and the connecting parts fastened and reliable.

The third level of maintenance refers to the annual checkup of the

machine. This should be done by the maintenance man with the cooperation of the operator. During this process, every part of the printer should be examined and adjusted thoroughly, and replacement made to the spares that are easily worn. The electric circuit and oil path should also be checked for their reliability.

The above 3-level system of maintenance should have concrete content and requirement, of which the first-level maintenance plays the most important role.

Parts List of Jingda Rotary Machine

Names	Qty.
Correction Panel	One
Rubber Roller	Twelve Pieces
Rubber Hammer	One
Special Wrench	One Pair
Rubber Blanket	Two
M4 Inner Angle	
Blade	One Bag
Blade Shank	One
M10*165	Twelve Pieces
Operation Instruction	One Copy
Ink Blade	One

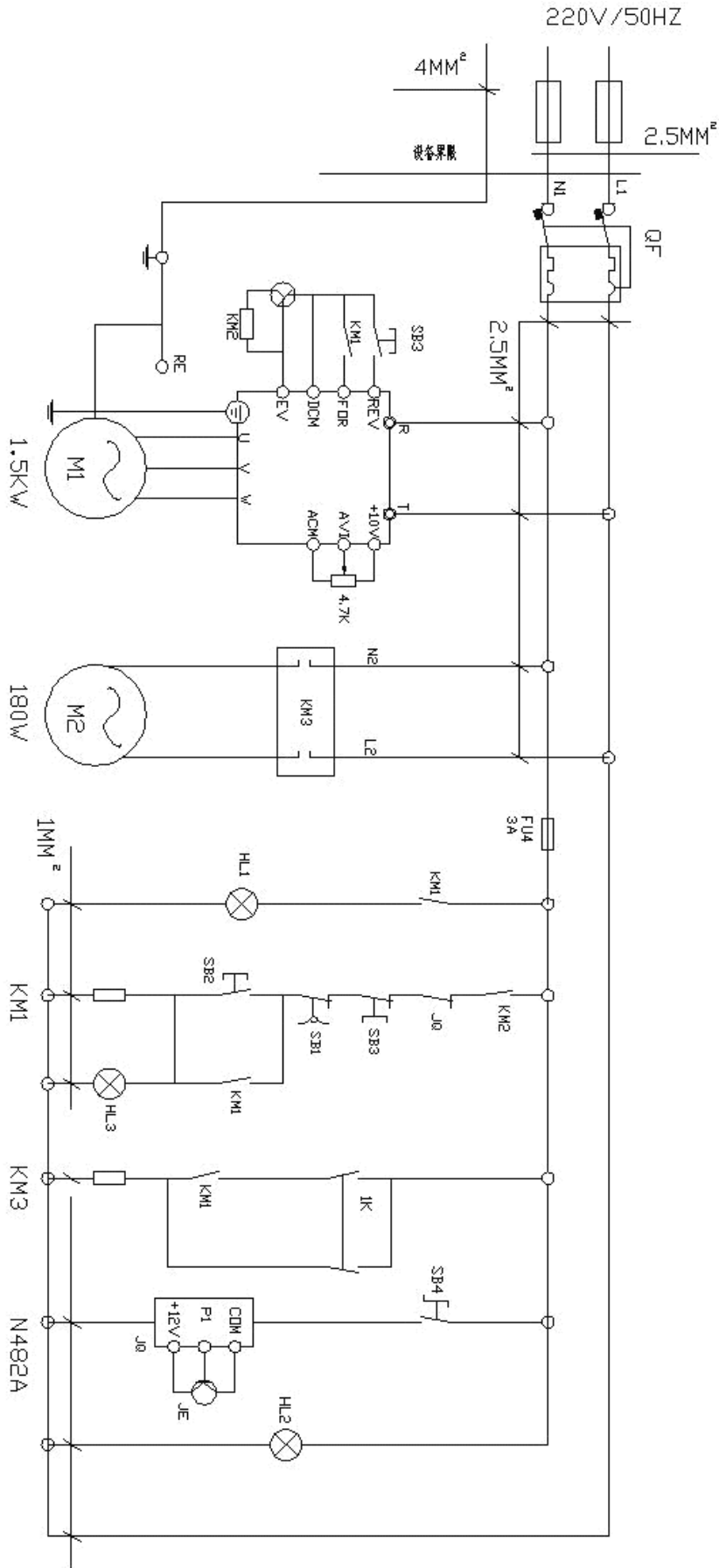

单相交流电源	电源开关	调速电动机	后备电机	照明	主接触器	热继电器	计数器	指示灯
--------	------	-------	------	----	------	------	-----	-----